



Turning 400 Years

The Worshipful Company of Turners of London

1604 ~ 2004

In 1295 there was in the City of London a Turners' Guild of craftsmen united to protect themselves and their craft. They made everyday necessities: goblets, platters, chairs, stools, measures, bowls; and they controlled the trade in the City, with power to search for and destroy any turned item lacking the mark of a Guild member.

In 1604 King James I of England (VI of Scotland) granted the Guild a Charter of Incorporation. In 2004, long after members of the Worshipful Company of Turners of London (as the Guild became) had stopped roaming the City's alleys looking for sub-standard turned measures to smash, the Company celebrated its 400th anniversary.



The Turners' Float: The longest float in the Lord Mayor's Show

In November 2003, as a prelude to the celebrations and at the request of the Lord Mayor, the Company entered a float in the Lord Mayor's Show. The drawings by Liveryman Andrea Cenci di Bello were highly commended by the Pageant Master, and the result was splendid to behold: a 20-tonne trailer decked in scaffolding and banners of Company blue and gold, pulled by a Foden Recovery Tractor, the ensemble 68' long. On the trailer stood a turned wooden wassail bowl 4' 6" high, containing not 90 gallons of good red wine but the Master, Andrew Mayer, loosening his grip on the rim only to wave at the cheering crowds.

Also displayed were a treadle lathe rescued from a monk's cell during the refurbishment of a Sussex monastery, the modern lathe on which Stephen Cooper RPT had turned the giant wassail bowl, a shave horse, a bodger's shelter housing a pole lathe, and a massive cartwheel minus the spikes with which the Company's patron saint, Catherine, was tortured.

Forty whiffers of all ages (one in a knapsack on her father's back) dressed in Small, Medium or Large blue fleeces adorned with the Company crest, escorted the float to huge applause. The anniversary celebrations had begun in style.

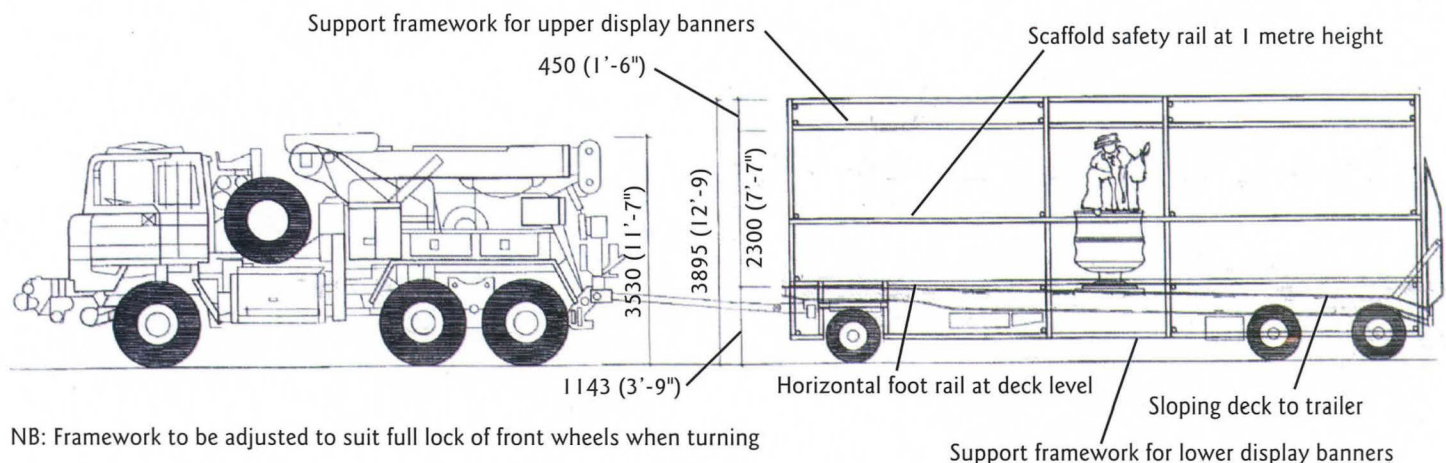

The Finest Turning Competitions

On June 14th 2004 the Company's Turning Competitions were held in the beautiful setting of Apothecaries' Hall. The entries are always impressive, being the work of Britain's finest turners, and for the anniversary they were of particularly high quality. There were all kinds of wood in colours from near white to purple (a wood called *Purpleheart*) and the deep reddish-black of rosewood, styles both traditional and ultra-modern, pieces of great weight alongside translucent wood turned to paper thinness, highly intricate objects turned on an ornamental lathe contrasting with the purest and simplest of lines created by plain turning. The judges were called on to make Solomonic judgements in reaching their decisions.

It was a day of bustle and excitement, with practising turners arriving from all parts of the country, unpacking their cherished pieces, going away while the displays were set up, and returning to find out the results of the judging, and to take part in the prize-giving.

Two years earlier, when Aldermanic Sheriff, the Lord Mayor had attended the Turning Competitions and been so impressed that he asked to return; and we were honoured to see him again and to watch him awarding the gold, silver and bronze medals, cheques, certificates and vouchers given by the Company and by sponsors. Some of the prize-winners had been turning for decades, some were younger, such as winners of the Company's Bursaries, some under 18 and just beginning. All were as enthusiastic about the glories of the Craft as the members of the Company who were at this feast to the eye and hand.

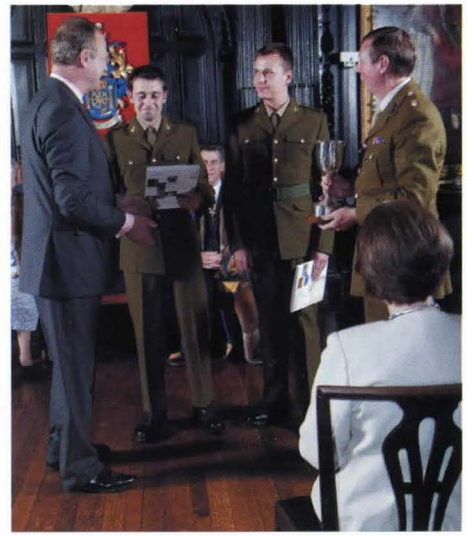

Above The Lord Mayor, Robert Finch, presenting one of three prizes to the armed services.

Left The Lord Mayor admires the competition entries for the Felix Levy competition, with the Master of the Company, Richard Levy, and Renter Warden Penrose Halson.

Below The Master inspects the winning entry in the Master's Competition.

Bottom A piece from the Company's Howe Collection, turned by the late Fred Howe.

Right Paul Coker RPT took first prize in the Master's Competition for a Turned Egg in honour of Honorary Liveryman Theo Fabergé with his stunning egg-shaped lidded goblet.

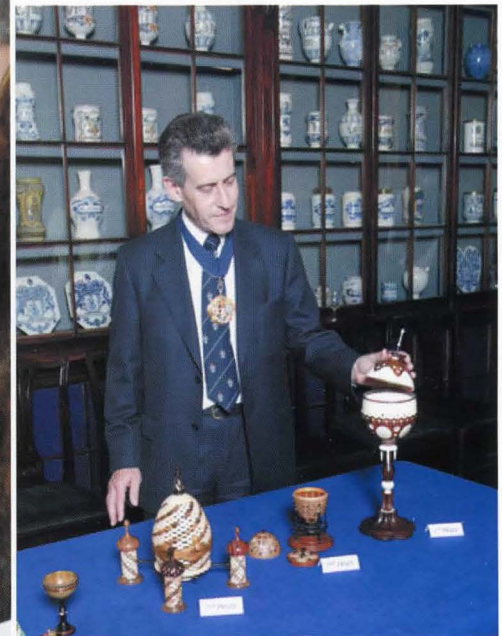
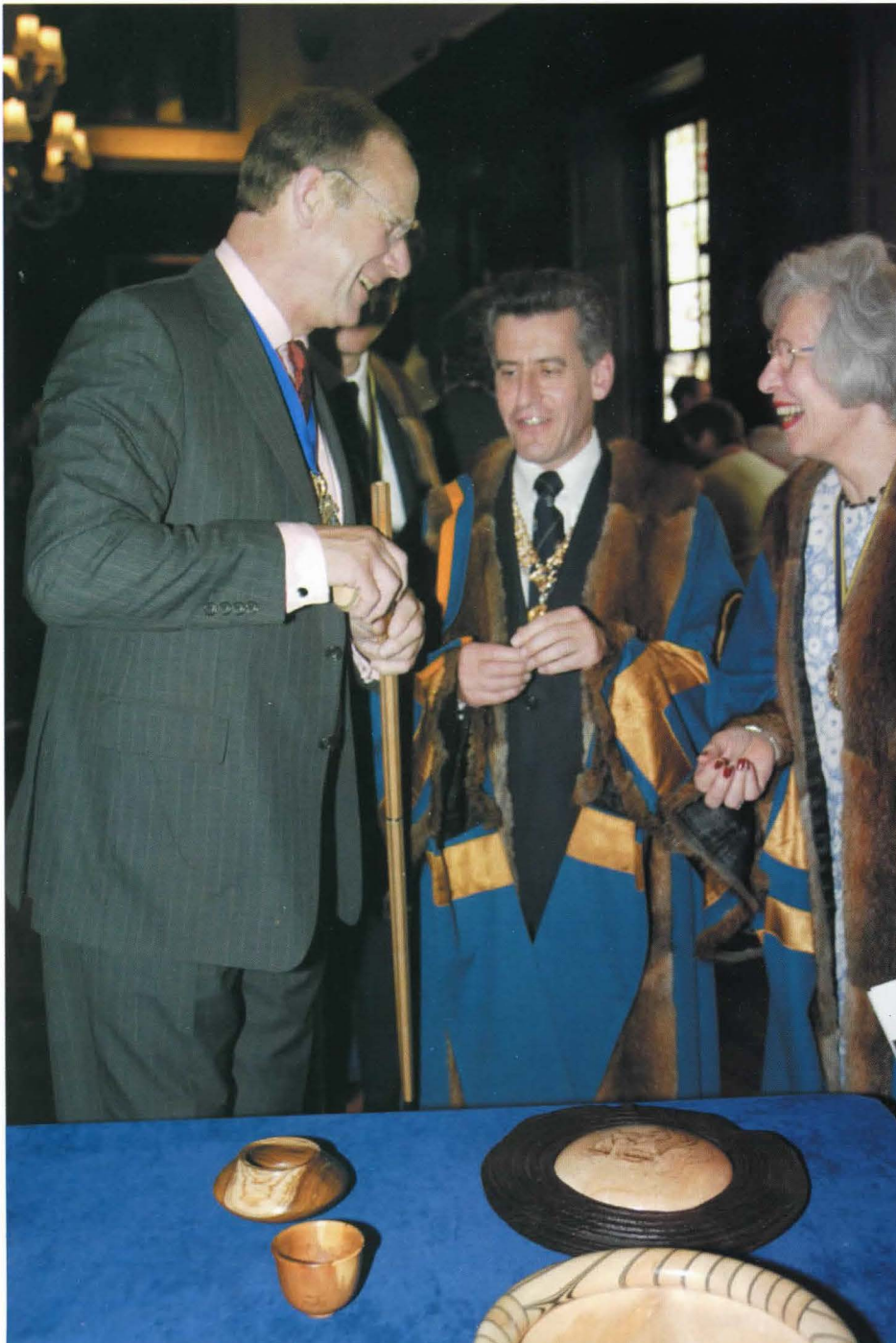

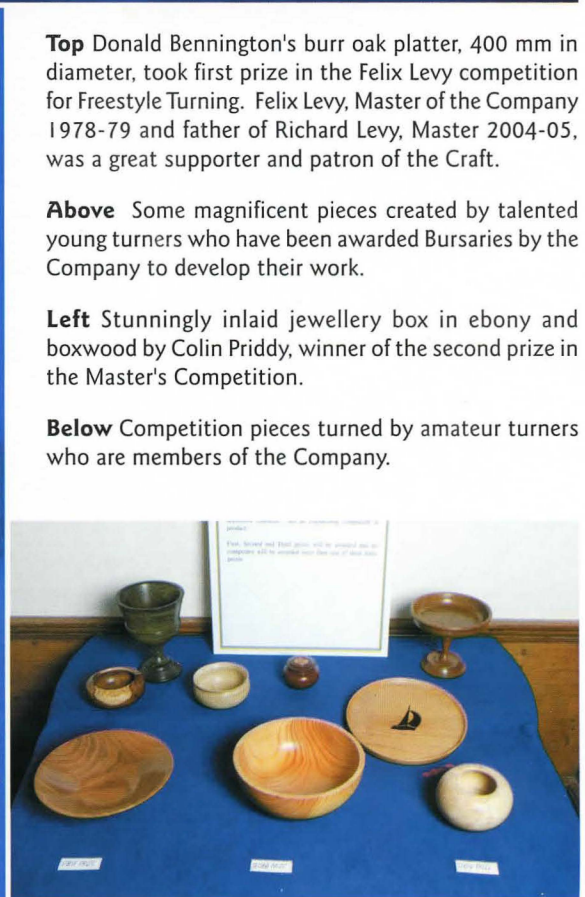
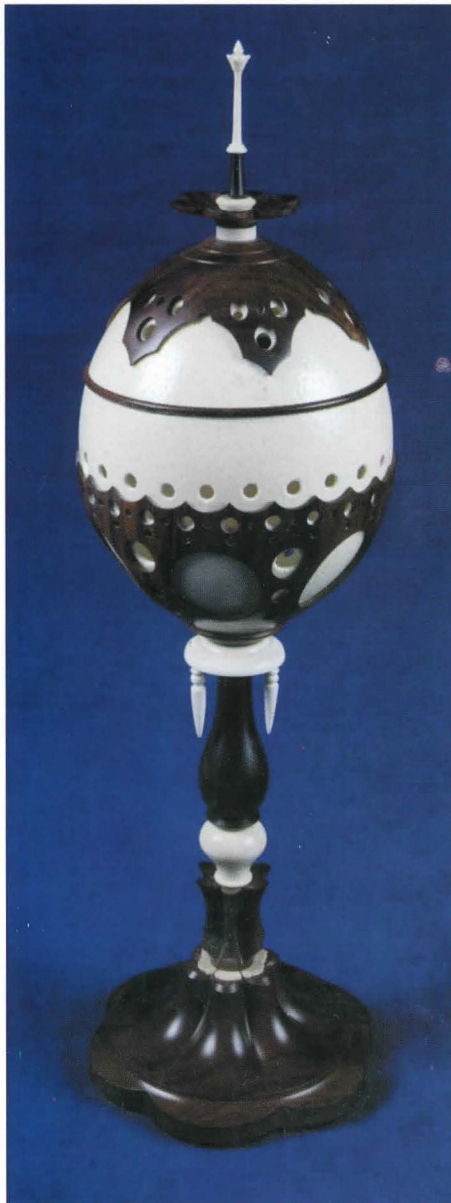

Top Donald Bennington's burr oak platter, 400 mm in diameter, took first prize in the Felix Levy competition for Freestyle Turning. Felix Levy, Master of the Company 1978-79 and father of Richard Levy, Master 2004-05, was a great supporter and patron of the Craft.

Above Some magnificent pieces created by talented young turners who have been awarded Bursaries by the Company to develop their work.

Left Stunningly inlaid jewellery box in ebony and boxwood by Colin Priddy, winner of the second prize in the Master's Competition.

Below Competition pieces turned by amateur turners who are members of the Company.

Wizardry in Wood

The day after the Turning Competitions, *Wizardry in Wood* opened at Pewterers' Hall. It was magnificent, an exhibition of fine turning such as has seldom been seen before anywhere in the world. In only two and a half days it attracted more than a thousand visitors, many of whom came out of curiosity but stayed on to admire the fine turned articles displayed by Britain's top turners, and to watch the demonstrations on many kinds of lathe, including a full-size reconstruction of a lathe drawn by Leonardo da Vinci.

Lord Linley came to *Wizardry in Wood* and caused some concern among his staff by staying far longer than scheduled, talking with the professional turners and lingering over the wonderful works on display. There were superb items from the Company's historic collection of fine turned items, turned musical instruments (thanks to the Worshipful Company of Musicians), splendid and varied objects from private collections, including those of Honorary Liveryman Theo Fabergé & his daughter, designer Sarah Fabergé, Jonathon Cuff & Shirley Sinclair who focus mainly on British turning, Brian & Hana Smouha who specialize in largely American pieces, Freeman Stuart King RPT, the *Register of Professional Turners*, the *Association of Wood Turners of Great Britain*, the *Society of Ornamental Turners* and the *Association of Pole-lathe and Greenwood Turners*.

The exhibition clearly had a major effect in raising awareness and appreciation of fine turning. The Master, Richard Levy, reports "I have had a large number of letters from the Masters of other Livery Companies complimenting the Turners on the quality of *Wizardry in Wood*, many confessing that they were unable to resist buying items and wishing that they had bought more. When is the next exhibition, they ask me!"



Above Theo Fabergé's Shtandart Egg, commemorating Peter the Great's ship, the *Shtandart*. The turned oak exterior, decorated with vermeil rope, ship's wheel and anchor, conceals the ship's compass.

Left From the St Petersburg Collection: the Four Seasons eggs designed by Sarah Fabergé, engine-turned silver and gold painted by hand and fired with layers of translucent enamel. Each egg contains a surprise: the Spring Egg (yellow), a snail; Summer (green), a butterfly; Autumn (royal blue), a ladybird; Winter (cobalt blue), red berries.

Bottom Left Lord Linley deep in conversation with star turner Bert Marsh in Pewterers' Hall.

Bottom An elegant piece from the collection of Brian & Hana Smouha: Gianfranco Angelini's pine and epoxy resin bowl.

Opposite Page

Top Left A selection from the Daniel Collection (lent by leading British collectors Shirley Sinclair and Jonathon Cuff).

Middle Left and Upper Right Stanesby Junior, Freeman of the Turners' Company in 1691, made the flute of which this copy was turned by Mathew Dart, maker of bassoons and flutes after 18th-century originals.

Bottom Left Freeman Stuart King RPT, an authority on the history of the Craft and a practising turner, was relieved to find that Leonardo's lathe really worked, and turned several small bowls on the spot!

Top Right From the collection of Brian & Hana Smouha: Philip Moulthrop's mosaic bowl, made by applying one-inch-thick cross-sectioned discs of wood to a bowl form and filling in around them with dark wood resin.

Lower Right A modern ornamental lathe being demonstrated by Bob Wade of the Society of Ornamental Turners.

Bottom Right The huge Wassail Bowl, transferred from the Float to the Exhibition, is admired by Upper Warden Andrew Ciclitira.



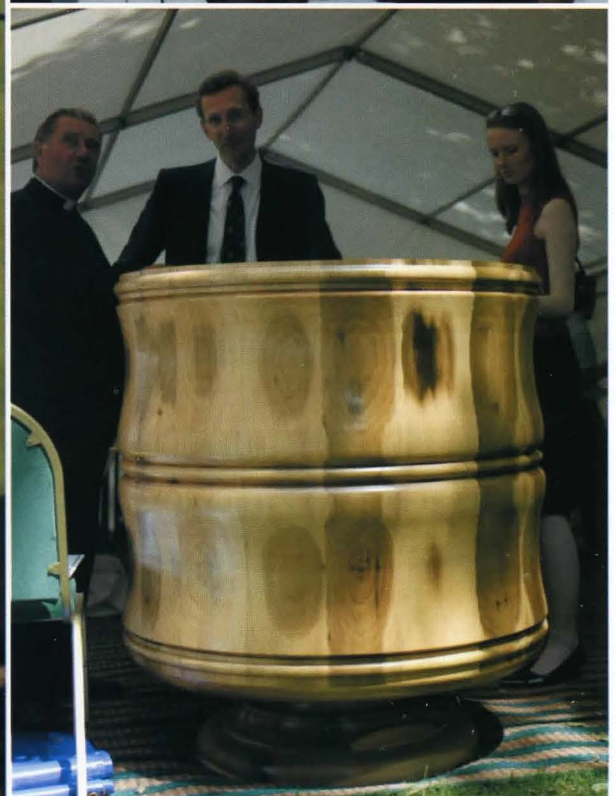

Turning the next 400 Years

The Worshipful Company of Turners of London

2004 ~

2004 was a turning point for the Worshipful Company of Turners. Our 400th anniversary added an extra intensity to the members' focus on our role in supporting the three Cs: our Craft, the City of London and Charity.

The Company had not mounted a float in the Lord Mayor's Show since 1911. It had not held an exhibition as comprehensive as *Wizardry in Wood* since the nineteenth century. The 2004 Turning Competitions were especially splendid and well supported. So building on the success of our anniversary events, we are expanding our existing activities and adding new ones:

Register of Professional Turners

Since 1978 the Company has supported the *Register of Professional Turners*, which lists professional turners all over the UK whose work has been approved by a Company assessor. Consult the RPT to buy a marvellous ready-made turned object, such as a perfect salad bowl, or to commission a special wedding present, sports trophy or commemorative retirement piece, or to repair a damaged piece of precious furniture.

Bursaries

The Company awards Bursaries to promising turners who are extending the technical and design boundaries of the Craft. Bursaries buy time and freedom. "I was (still am) thrilled to have been a winner of this bursary award. It has brought great changes to my working life as an artist/woodturner," wrote a recent Bursary winner.

Turning Competitions

The Company's first competitions, in 1857, attracted two entries (both fishing rods). Today our biennial Turning Competitions attract the finest turning by Britain's top turners. The Junior class for turners under 18 is increasingly popular, and more and more young women are practising the Craft.

Wood-turning associations

The Company has close links with Craft associations. The President of the *Association of Woodturners of Great Britain*, internationally-known woodturner Ray Key, is a Freeman of the Company, as too is John Edwards, leading turner and President of the *Society of Ornamental Turners*.

The City

Born and bred in the City of London, the Livery Companies support the City's unique system of governance, headed by the Lord Mayor. Members of the Turners' Company give to the Lord Mayor's charities, attend City functions, often work, live or worship in the City, and are interested in its history, culture and financial life.

Exhibitions & showcases

With the RPT, the Company exhibits at national woodworking shows. The success of *Wizardry in Wood* set the Company thinking about a further exhibition of our own. We have a showcase in Tower 42 (formerly the NatWest Tower), in the City and more showcases and demonstrations of the Craft are in the pipeline.

Publications

In 2004 Past Master Brian Burnett brought the Company's history up to date. This herculean task resulted in a fascinating book recording the ups and downs of the Company and the Craft. The Company has given a grant to Robin Wood, historian and practitioner of woodturning, to produce a fascinating and comprehensive book, *The Wooden Bowl*, published in 2005.

Website

The Company's website continues to improve, and is developing into a very effective way of communicating with members and informing the public.



Liveryman Malcolm Cobb, scientist, Company Gold Medallist and Secretary of the RPT, encouraging young turner Yvonne Arlott at a national show.



The box of African blackwood inlaid with boxwood turned by renowned ornamental turner Paul Coker RPT, to commemorate our 400th anniversary.



The portable font by Liveryman and Company Gold Medallist Philip Holden and Allan Beecham RPT, presented by the Turners' Company to St Brides's, Fleet Street, to celebrate the Millennium. The church added a glass top, enabling the font to be adorned with candles at Christmas. Canon David Meara is the Company's Honorary Chaplin.



Albert LeCoff of the Wood Turning Center, Philadelphia, with Mark Hancock RPT, whose Company Bursary enabled him to study in the USA.

Charity

The Company gives prizes, grants and lathes to organisations and individuals, for example to Lord Mayor Treloar College, Dorton House School for the Blind, the City of London Freemen's School and the Building Crafts College.

The Services

The Company has links with H.M.S. Sultan, R.A.F. Saint Athan, and particularly close links with the Royal Electrical and Mechanical Engineers. The Turners' Shield is awarded to the winners of REME Southern Command's annual three-day competition for teams of Territorials competing in nine military disciplines. The first awards for a new competition for the REME soldiers of both the Regulars and Territorials were presented at the Ladies' Dinner in the Mansion House in 2004.

Learning Turning

Turning is a great hobby that the Company encourages people to learn. *The Register of Professional Turners* and the *Association of*



Theo Fabergé being created Honorary Liveryman in Apothecaries' Hall

Wood Turners of Great Britain publish lists of professional turners who teach.

Transatlantic Turners

In the USA fine turning is more than a craft; it is a highly-prized art form. Up-and-coming British turners go there to study, and top turners exhibit and sell to American collectors. The Company is developing closer links with American woodturners, particularly via our Bursary-winners.

Golf

The Turners' Golf Society plays in the two annual inter-Livery matches, the Prince Arthur Cup and the Newson-Smith Trophy, as well as hosting its own Society meeting. The members enjoy both the golf and the conviviality of their meetings.

Livery Companies Wood Group

The Turners set up a group of Companies whose Craft includes work in wood (Furniture Makers, Upholders, Carpenters etc). The Group shares a large stand at the Alexandra Palace woodworking show, awards prizes and arranges visits, for example to the unique Frederick Parker Chair Collection.

Other Livery Companies

The Company has the pleasure and privilege of holding Court meetings, lunches and dinners in Apothecaries' Hall, the oldest extant Livery Hall; *Wizardry in Wood* was held in Pewterers' Hall; at Christmas we join the Musicians' Company in their carol service at St Michael's, Cornhill.



Past Master Brian Burnett MC MA, distinguished historian of the Company.

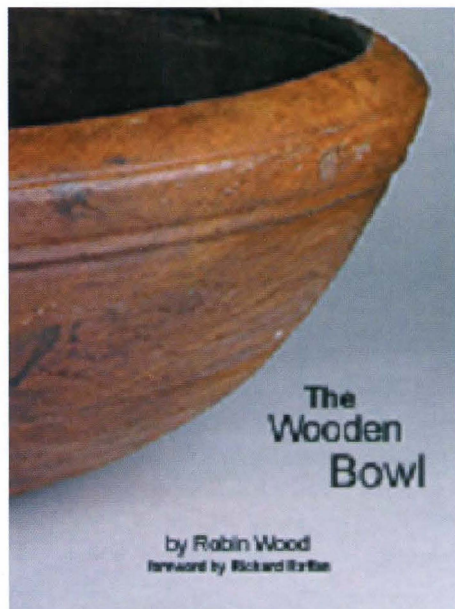

Robin Wood's definitive study of turned wooden bowls from the Iron Age to the 21st century, published by Stobart Davies.



Liveryman Alan Mitchell receiving a turned plate signed by innumerable turners thanking him for his untiring work in organizing exhibitions.



Demand for tickets for the Ladies' Dinner in 2004 was so great that there was not enough room in Apothecaries' Hall, so the Company and guests dined in the Mansion House.



The showcase in Tower 42 holds an ever-changing display of the best modern turnery.



Lt Col John Power, Commanding Officer of 5 Bn REME, holding the Turners' Trophy (a magnificent wassail bowl turned in lignum vitae) at the Mansion House.



The Company gave to Lord Mayor Treloar College a computer-controlled lathe specially adapted for use by disabled students.

Websites to Watch

Worshipful Company of Turners of London	www.TurnersCo.com
Association of Woodturners of Great Britain	www.WoodTurners.co.uk
Society of Ornamental Turners	www.The-SOT.com
Association of Pole-lathe Turners and Greenwood Workers	www.Bodgers.org.uk
Daniel Collection	www.TheDanielCollection.com
Register of Professional Turners	www.RPTurners.co.uk
Saint Petersburg Collection	www.StPetersburgCollection.com
Sarah Myerscough Gallery	www.SarahMyersCough.com
Corporation of London	www.CityofLondon.gov.uk
Wood Turning Center	www.WoodTurningCenter.org
Stobart Davies	www.StobartDavies.com

Hospitality

The Turners are renowned for their friendliness and warmth of welcome to visitors, at both informal events (of which the Company has several each year) and formal dinners. "Seldom have I eaten so well, met so many charming and interesting people and been made to feel such an integral part of the occasion," wrote a guest at the Ladies' Dinner in 2004. "I toast the Turners' next 400 years!"

Please Contact

If you would like to receive:

- rules and entry forms for the Company's **Bursaries** or **Turning Competitions**
- general information about the **Company**, and **membership**
- information about **future exhibitions** and **other events**

please contact the Company's website or:

The Clerk
Worshipful Company of Turners
182 Temple Chambers
Temple Avenue
London EC4Y 0HP
Telephone 020 7353 9595
Email clerk@turnersco.com

The Company thanks the following for use of their photographs and drawings and acknowledges their respective copyrights:

Andrea Cenci di Bello (p 1); St Petersburg Collection (p 4); Smouha Collection (p 4 & 5); Mathew Dart (p 5); Daniel Collection (p 5); St Bride's (p 6); Bill Halson (p 6 & 7) Mark Hancock (p 7); Robin Wood (p 7); Lord Mayor Treloar College (p 8); Peter Ellis (p 8)

THANK YOU

Thanks to many who generously gave their time, effort and skill, our 400th anniversary was a great success. The celebrations have given the Company's main objective, the promotion of the Craft of turning, a significant boost, and have greatly enhanced the profile of both the Craft and the Company.

Our hearty thanks go to all those individuals and organisations mentioned on these pages so far, and to many others, too numerous to detail, but particularly including Assistant George Kieffer and the Livery Committee for organising *Wizardry in Wood*, Assistant Robert Lucas and the Howe Committee for running the Turning Competitions, and our indefatigable Clerk, Edward Windsor Clive. We are also indebted to the individual professional turners who displayed and demonstrated their work, the Saint Petersburg Collection, the staff of Apothecaries' Hall and of Pewterers' Hall, Tom Pockley RPT, Tim Cranmore and Mark Baigent, the Rev David Paton of Saint Vedast, Andrew Michael for his photographs, Liveryman Michael Steinbeck-Reeves for the Newsletter, Assistant Peter Gibson and Liveryman Tony Johns for their work on the website, Past Master Tony Crooks-Meredith for the production of our History, Past Master Colin Field for the organisation of the Float.

We are also grateful to contributors and sponsors who generously gave anything from scaffolding for the Float to vouchers for competition-winners, via gallons of teak oil to finish the Wassail Bowl, the largest in the world (as far as we know!). They include: Ashley Iles (Edge Tools) Ltd, Axminster Power Tool Centre, Liveryman Clifford Champion, Craft Supplies, GMC Publications, Highbury Leisure, Liberon Waxes, Record Power, REME, Rustins Ltd, Sorbys.

To all who helped us to make the *mystery or art of turning* less of a mystery and more of an art: THANK YOU.



Andrew Mayer Master, 2003 – 2004

Andrew Mayer



Richard Levy, Master 2004 – 2005

Richard Levy